

SURFACE PROCESSING

mvt AG offers a comprehensive, economically-priced range of diamond nozzles for the most varied of applications in the field of surface processing. All of our nozzles consist of a stainless steel nozzle body with a sapphire orifice. Their special design gives them a high degree of stability and safety. Special designs and customer-specific solutions are available on request.

PROPERTIES AND ADVANTAGES

- ▶ Long lifetime, approximately 20 times longer than sapphire nozzles
- ▶ Consistent jet quality
- ▶ Precision cutting accuracy
- ▶ Narrow cut width
- ▶ High cutting performance
- ▶ Longer lifetime of focusing tube
- ▶ Excellent price-to-performance ratio
- ▶ Swiss quality

CUSTOMER BENEFITS

- ▶ High productivity
- ▶ Minimal downtime
- ▶ Cost-effective manufacturing
- ▶ High quality standard
- ▶ Expert advice
- ▶ Reliable service

APPLICATIONS

- ▶ Automotive and aircraft industry
- ▶ Construction
- ▶ Mining
- ▶ Chemistry
- ▶ Iron, steel and metal industry
- ▶ Energy
- ▶ Drink
- ▶ Glass, porcelain and ceramics industry
- ▶ Wood industry
- ▶ Local firms
- ▶ Agriculture
- ▶ Machinery and Apparatus
- ▶ Food Processing
- ▶ Offshore Operations
- ▶ Shipbuilding
- ▶ Transportation
- ▶ Pulp and Paper Industry
- ▶ Cement and Concrete Industry

Max. 1000 bar

Included assembly screw

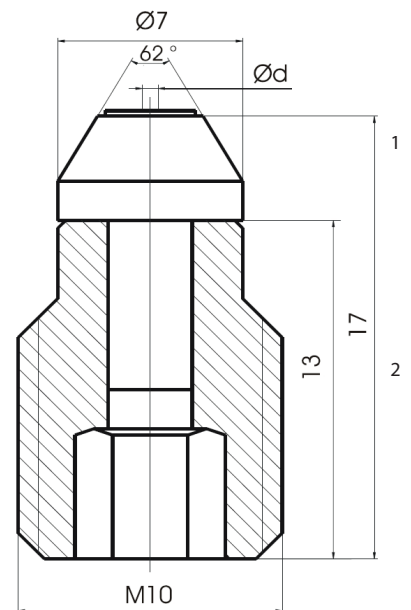

1. Nozzle
2. Assembly screw (Stainless) Best. Nr 10099

PERFORMANCE

Nozzle size in U.S. Gal / min at 40 psi	Nozzles Ød mm	Pressure in bar							
		200	500	750	1000	1500	2000	2500	3000
		Density of water							
		kg/m ³	kg/m ³	kg/m ³	kg/m ³	kg/m ³	kg/m ³	kg/m ³	kg/m ³
		1010.03	1020.68	1029.37	1037.9	1054.48	1070.4	1085.68	1100.3
		l/min	l/min	l/min	l/min	l/min	l/min	l/min	l/min
0002	0.10	0.064	0.100	0.122	0.141	0.171	0.196	0.217	0.237
0003	0.125	0.092	0.144	0.176	0.203	0.146	0.282	0.313	0.341
0004	0.15	0.143	0.226	0.275	0.316	0.385	0.441	0.489	0.532
0006	0.175	0.184	0.290	0.354	0.407	0.494	0.566	0.628	0.684
0008	0.20	0.255	0.401	0.489	0.563	0.684	0.784	0.870	0.946
0012	0.25	0.399	0.627	0.764	0.879	1.068	1.224	1.359	1.479
0015	0.28	0.500	0.786	0.959	1.103	1.340	1.536	1.705	1.855
0018	0.30	0.574	0.903	1.101	1.266	1.538	1.763	1.957	2.130
0021	0.33	0.694	1.092	1.331	1.532	1.861	2.133	2.368	2.577
0024	0.35	0.781	1.229	1.498	1.723	2.094	2.400	2.664	2.899
0031	0.40	1.020	1.605	1.957	2.251	2.735	3.134	3.479	3.786
0040	0.45	1.291	2.031	2.477	2.848	3.461	3.967	4.403	4.792

INSTRUCTIONS

During manual operation of high-pressure spray guns and lances, which may be included recoil force in the longitudinal axis of the spray device may not exceed 250N!

If the recoil force is 150N, has been working with a body support!

	< 150 N
	< 250 N
	> 250 N