

WATER JET CUTTING

mvt AG offers a comprehensive, economically-priced range of diamond nozzles for the most varied of applications in the field of water jet cutting. All of our nozzles consist of a stainless steel nozzle body with a diamond orifice. Their special design gives them a high degree of stability and safety. Special designs and customer-specific solutions are available on request.

PROPERTIES AND ADVANTAGES

- ▶ Long lifetime
- ▶ Consistent jet quality
- ▶ Precision cutting accuracy
- ▶ Narrow cut width
- ▶ High cutting performance
- ▶ Longer lifetime of focusing tube
- ▶ Excellent price-to-performance ratio
- ▶ Swiss quality

CUSTOMER BENEFITS

- ▶ High productivity
- ▶ Minimal downtime
- ▶ Cost-effective manufacturing
- ▶ High quality standard
- ▶ Expert advice
- ▶ Reliable service

APPLICATIONS

Metal, titanium, aluminium, stone, marble, granite, ceramics, rock wool, reinforced concrete, plaster, laminated glass, safety glass, wood, plastics, bullet-proof glass, composites, automotive and aircraft parts, etc.

Mixing chamber Typ 702

Max. 4000 bar

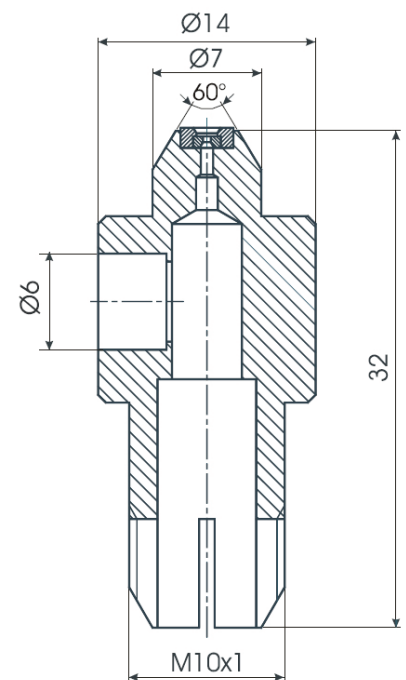
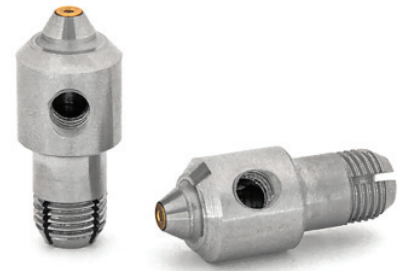

Nozzles Ø mm

0.25	0.28	0.30	0.33	0.35	0.40	0.45
------	------	------	------	------	------	------

The mixing chamber Type 702 fits onto the abrasive cutting Type 544 and 545.