

SURFACE PROCESSING

mvt AG offers a comprehensive, economically-priced range of sapphire nozzles for the most varied of applications in the field of surface processing. All of our nozzles consist of a stainless steel nozzle body with a sapphire orifice. Their special design gives them a high degree of stability and safety. Special designs and customer-specific solutions are available on request.

PROPERTIES AND ADVANTAGES

- ▶ Long lifetime
- ▶ Consistent jet quality
- ▶ Precision cutting accuracy
- ▶ Narrow cut width
- ▶ High cutting performance
- ▶ Longer lifetime of focusing tube
- ▶ Excellent price-to-performance ratio
- ▶ Swiss quality

CUSTOMER BENEFITS

- ▶ High productivity
- ▶ Minimal downtime
- ▶ Cost-effective manufacturing
- ▶ High quality standard
- ▶ Expert advice
- ▶ Reliable service

APPLICATIONS

- ▶ Automotive and aircraft industry
- ▶ Construction
- ▶ Mining
- ▶ Chemistry
- ▶ Iron, steel and metal industry
- ▶ Energy
- ▶ Drink
- ▶ Glass, porcelain and ceramics industry
- ▶ Wood industry
- ▶ Local firms
- ▶ Agriculture
- ▶ Machinery and Apparatus
- ▶ Food Processing
- ▶ Offshore Operations
- ▶ Shipbuilding
- ▶ Transportation
- ▶ Pulp and Paper Industry
- ▶ Cement and Concrete Industry

Sapphire screw-in nozzles Type 965

Max. 3000 bar

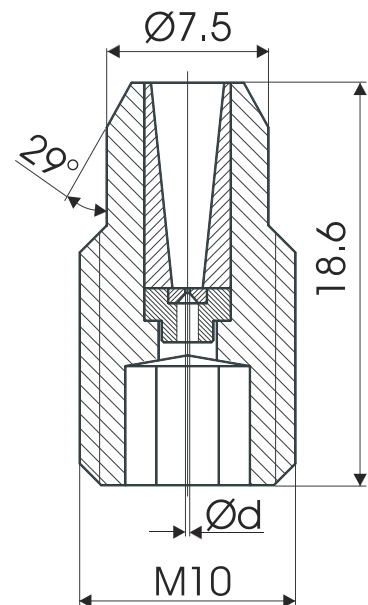

## PERFORMANCE

Nozzle size in U.S. Gal / min at 40 psi	Nozzles Ød mm	Pressure in bar							
		200	500	750	1000	1500	2000	2500	3000
		Density of water							
		kg/m <sup>3</sup>	kg/m <sup>3</sup>	kg/m <sup>3</sup>	kg/m <sup>3</sup>	kg/m <sup>3</sup>	kg/m <sup>3</sup>	kg/m <sup>3</sup>	kg/m <sup>3</sup>
		1010.028	1020.675	1029.36875	1037.9	1054.475	1070.4	1085.675	1100.3
	l/min	l/min	l/min	l/min	l/min	l/min	l/min	l/min	
0002	0.10	0.064	0.100	0.122	0.141	0.171	0.196	0.217	0.237
0003	0.125	0.100	0.157	0.191	0.220	0.267	0.306	0.340	0.370
0004	0.15	0.143	0.226	0.275	0.316	0.385	0.441	0.489	0.532
0006	0.175	0.197	0.309	0.377	0.434	0.527	0.604	0.671	0.730
0008	0.20	0.255	0.401	0.489	0.563	0.684	0.784	0.870	0.946
0012	0.25	0.402	0.632	0.771	0.887	1.078	1.235	1.371	1.492
0018	0.30	0.574	0.903	1.101	1.266	1.538	1.763	1.957	2.130
0025	0.35	0.808	1.270	1.549	1.781	2.165	2.481	2.754	2.997
0032	0.40	1.026	1.614	1.969	2.264	2.751	3.153	3.500	3.808
0040	0.45	1.301	2.046	2.495	2.869	3.486	3.996	4.436	4.827
0050	0.50	1.638	2.577	3.143	3.614	4.391	5.032	5.587	6.079
0061	0.55	1.982	3.118	3.802	4.373	5.313	6.089	6.760	7.356
0072	0.60	2.343	3.685	4.494	5.168	6.280	7.197	7.990	8.694
0085	0.65	2.769	4.355	5.311	6.107	7.421	8.505	9.442	10.274
0098	0.70	3.200	5.034	6.139	7.060	8.578	9.831	10.914	11.876
0114	0.75	3.700	5.820	7.098	8.162	9.918	11.367	12.619	13.731
0131	0.80	4.261	6.702	8.174	9.399	11.421	13.090	14.531	15.812
0148	0.85	4.810	7.566	9.228	10.611	12.893	14.777	16.404	17.850
0166	0.90	5.401	8.495	10.360	11.913	14.475	16.590	18.417	20.040
0187	0.95	6.094	9.584	11.689	13.441	16.332	18.718	20.780	22.611
0213	1.00	6.930	10.900	13.293	15.287	18.574	21.288	23.632	25.715
0258	1.10	8.39	13.19	16.08	18.50	22.48	25.76	28.60	31.12
0307	1.20	9.99	15.72	19.17	22.04	26.78	30.70	34.08	37.08
0361	1.30	11.73	18.45	22.50	25.87	31.43	36.02	39.99	43.52
0418	1.40	13.60	21.39	26.09	30.00	36.46	41.78	46.38	50.47
0480	1.50	15.61	24.56	29.95	34.44	41.85	47.96	53.24	57.94
0546	1.60	17.76	27.94	34.08	39.19	47.61	54.57	60.58	65.92
0617	1.70	20.05	31.54	38.47	44.24	53.75	61.60	68.39	74.42
0684	1.80	22.24	34.98	42.66	49.06	59.61	68.32	75.84	82.53
0771	1.90	25.05	39.40	48.05	55.26	67.14	76.95	85.43	92.96
0854	2.00	27.76	43.66	53.25	61.23	74.40	85.27	94.66	103.00
0941	2.10	30.60	48.13	58.70	67.50	82.02	94.01	104.36	113.56
1106	2.20	35.95	56.54	68.95	79.29	96.35	110.42	122.58	133.39
1205	2.30	39.19	61.64	75.17	86.45	105.04	120.38	133.64	145.42
1313	2.40	42.67	67.12	81.85	94.13	114.37	131.08	145.52	158.34
1424	2.50	46.30	72.83	88.82	102.13	124.10	142.23	157.90	171.81
1540	2.60	50.08	78.77	96.06	110.47	134.23	153.84	170.78	185.83
1661	2.70	54.01	84.95	103.60	119.13	144.75	165.90	184.17	200.40
1787	2.80	58.08	91.35	111.41	128.12	155.67	178.41	198.06	215.52
1916	2.90	62.30	98.00	119.51	137.43	166.99	191.39	212.46	231.19
2051	3.00	66.67	104.87	127.90	147.07	178.71	204.81	227.37	247.41

## INSTRUCTIONS

During manual operation of high-pressure spray guns and lances, which may be included recoil force in the longitudinal axis of the spray device may not exceed 250N!

If the recoil force is 150N, has been working with a body support!

	< 150 N
	< 250 N
	> 250 N