

SURFACE PROCESSING

mvt AG offers a comprehensive, economically-priced range of sapphire nozzles for the most varied of applications in the field of surface processing. All of our nozzles consist of a stainless steel nozzle body with a sapphire orifice. Their special design gives them a high degree of stability and safety. Special designs and customer-specific solutions are available on request.

PROPERTIES AND ADVANTAGES

- ▶ Application up to max. 3000bar and 24l/min
- ▶ For cutting:
 - Reinforced concrete up to 1 m thickness
 - Steel up to 80mm thickness
- ▶ Hardened mixing chamber for long life
- ▶ Water nozzle interchangeable
- ▶ Water nozzle and abrasive nozzles are factory pre-centered
- ▶ Water nozzle with sapphire
- ▶ Abrasive nozzle Carbide
- ▶ All parts are also available individually as replacement

BENEFITS

- ▶ Long life
- ▶ Constant jet quality
- ▶ Precise cutting accuracy
- ▶ Precise cut
- ▶ High cutting performance
- ▶ Excellent price-to-performance ratio
- ▶ Swiss Quality

APPLICATION

- ▶ Stone, marble, granite, ceramics, concrete, plaster, etc.

Ø Nozzle	Order. no.	l/min at 2000 bar	l/min at 2500 bar	l/min at 3000 bar	Focusing tube Ø
0.75	1100-0.75	11.180	12.412	13.506	2.00
0.80	1100-0.80	12.721	14.122	15.367	2.50
0.85	1100-0.85	14.631	15.942	17.347	2.50
0.90	1100-0.90	16.100	17.873	19.448	2.50
0.95	1100-0.95	17.938	19.914	21.669	3.00
1.00	1100-1.00	19.876	22.065	24.010	3.00

SPARE PARTS

A	B	C	D	E
Saphir Insert Nozzle Order. no.	Mixing chamber Order. no.	Abrasive unions Order. no.	Nut Order. no.	Focusing tube Order. no.
Type 952	Type 1100	Type 1140.02.00	1307.02.00	Type 1150

Max. 3000 bar

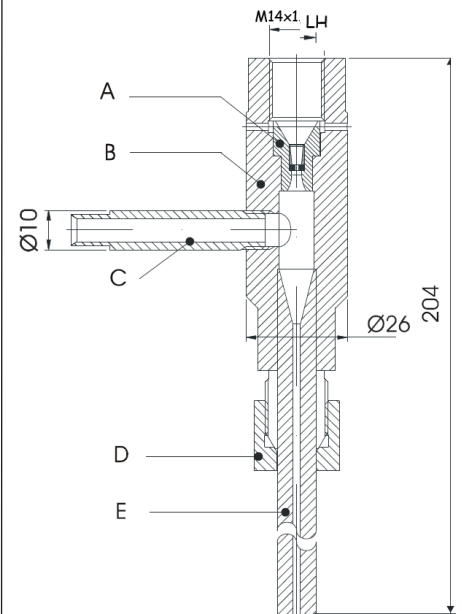

Abrasive cutting head Type 1100

Order No. 1100.01.00

Delivery

	Article	Order. No.
1	Saphir Insert Nozzle	Type 952 Ø0.80
1	Mixing chamber	Type 1100
1	Abrasive unions	1140.02.00
1	Nut	1307.02.00