

**WATER JET CUTTING**

MVT launched the first auto-aligned abrasive cutting head back in 1993. This innovative concept, combines a limited number of assembled components with precision machining. Although it inspired other companies to copy the idea, is still abrasiv head of the field in terms of price/performance ratio.

The MVT abrasive head keeps the water jet and the focusing nozzle constantly aligned without the need for any further adjustment. When the focusing nozzle or mixing chamber plus integrated sapphire nozzle is changed, no readjustment is necessary yet the jet remains perfectly aligned – benefits much appreciated in a production environment.

The original design and geometry of the mixing chamber for the MVT cutting head ensure optimal cutting performance und is intended for pressures of up to 4000 bar. This head can be mounted on every current make of machine – and that includes yours!

**PROPERTIES AND ADVANTAGES**

- ▶ User-friendly
- ▶ Reliable
- ▶ Efficiently
- ▶ Precise
- ▶ Uses less abrasive
- ▶ Shortens focusing nozzle changeover times
- ▶ Excellent price/performance ratio
- ▶ Ever-growing number of satisfied users

**APPLICATIONS**

metal, titanium, aluminium, stone, marble, granite, ceramics, reinforce concrete, plaster, rock wool, laminated glass, safety glass, bullet-proof glass, wood, plastics, composites, automotive and aircraft parts, etc

AbrasivcuttingheadsType540

Max. 4000 bar

Without focusing tube

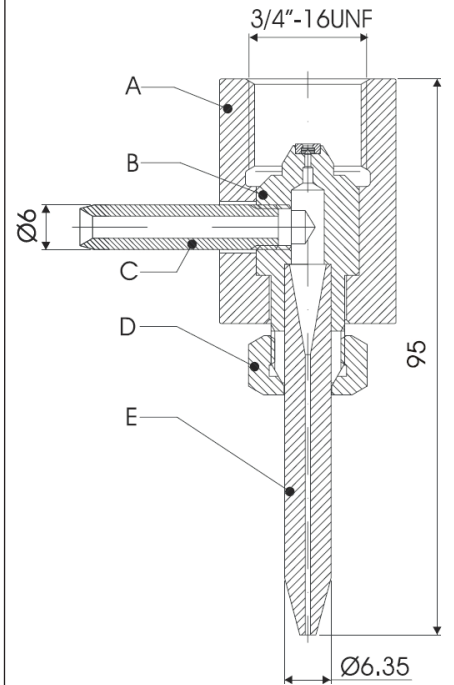

| Nozzles Ø mm |      |      |      |      |      |      |
|--------------|------|------|------|------|------|------|
| 0.25         | 0.28 | 0.30 | 0.33 | 0.35 | 0.40 | 0.45 |

**SPARE PARTS**

| A                           | B                            | C                             | D                 | E                           |
|-----------------------------|------------------------------|-------------------------------|-------------------|-----------------------------|
| Nozzle-holder<br>Order. no. | Mixing chamber<br>Order. no. | Abrasive unions<br>Order. no. | Nut<br>Order. no. | Focusing tube<br>Order. no. |
| 540.01.01                   | Type 700 - Ø 0.25            | 660.01.00                     | 640.01.00         | Duralife D                  |

Other jet diameters: See under Mixing chamber type 700  
Other focusing tube: See under focusing tube - Duralife D

**Abrasiv cutting heads Type 540**

Order. no. 540.01.00

**Delivery**

|   | Article         | Order. no.      |
|---|-----------------|-----------------|
| 1 | Nozzle-holder   | 540.01.01       |
| 1 | Mixing chamber  | Type 700 Ø 0.25 |
| 1 | Abrasive unions | 660.01.00       |
| 1 | Nut             | 640.01.00       |