

SURFACE PROCESSING

mvt AG offers a comprehensive, economically-priced range of sapphire nozzles for the most varied of applications in the field of surface processing. All of our nozzles consist of a stainless steel nozzle body with a sapphire orifice. Their special design gives them a high degree of stability and safety. Special designs and customer-specific solutions are available on request.

PROPERTIES AND ADVANTAGES

- ▶ Long lifetime
- ▶ Consistent jet quality
- ▶ Precision cutting accuracy
- ▶ Narrow cut width
- ▶ High cutting performance
- ▶ Longer lifetime of focusing tube
- ▶ Excellent price-to-performance ratio
- ▶ Swiss quality

CUSTOMER BENEFITS

- ▶ High productivity
- ▶ Minimal downtime
- ▶ Cost-effective manufacturing
- ▶ High quality standard
- ▶ Expert advice
- ▶ Reliable service

APPLICATIONS

- ▶ Automotive and aircraft industry
- ▶ Construction
- ▶ Mining
- ▶ Chemistry
- ▶ Iron, steel and metal industry
- ▶ Energy
- ▶ Drink
- ▶ Glass, porcelain and ceramics industry
- ▶ Wood industry
- ▶ Local firms
- ▶ Agriculture
- ▶ Machinery and Apparatus
- ▶ Food Processing
- ▶ Offshore Operations
- ▶ Shipbuilding
- ▶ Transportation
- ▶ Pulp and Paper Industry
- ▶ Cement and Concrete Industry

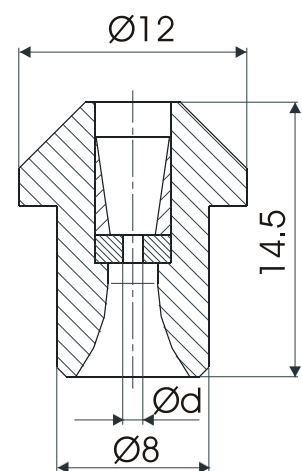

PERFORMANCE

Nozzle size in U.S. Gal / min at 40 psi	Nozzles Ød mm	Pressure in bar							
		200	500	750	1000	1500	2000	2500	3000
		Density of water							
		kg/m ³	kg/m ³	kg/m ³	kg/m ³	kg/m ³	kg/m ³	kg/m ³	kg/m ³
		1010.03	1020.68	1029.369	1037.9	1054.48	1070.4	1085.675	1100.3
		l/min	l/min	l/min	l/min	l/min	l/min	l/min	
0002	0.10	0.064	0.100	0.122	0.141	0.171	0.196	0.217	0.237
0003	0.125	0.100	0.157	0.191	0.220	0.267	0.306	0.340	0.370
0004	0.15	0.143	0.226	0.275	0.316	0.385	0.441	0.489	0.532
0006	0.175	0.195	0.307	0.375	0.431	0.523	0.600	0.666	0.725
0008	0.20	0.255	0.401	0.489	0.563	0.684	0.784	0.870	0.946
0012	0.25	0.399	0.627	0.764	0.879	1.068	1.224	1.359	1.479
0018	0.30	0.574	0.903	1.101	1.266	1.538	1.763	1.957	2.130
0024	0.35	0.781	1.229	1.498	1.723	2.094	2.400	2.664	2.899
0032	0.40	1.020	1.605	1.957	2.251	2.735	3.134	3.479	3.786
0040	0.45	1.303	2.049	2.499	2.874	3.492	4.002	4.442	4.834
0050	0.50	1.608	2.530	3.085	3.548	4.311	4.940	5.484	5.968
0060	0.55	1.946	3.061	3.733	4.293	5.216	5.978	6.636	7.221
0072	0.60	2.316	3.643	4.442	5.108	6.207	7.114	7.898	8.594
0084	0.65	2.718	4.275	5.214	5.995	7.285	8.349	9.269	10.086
0098	0.70	3.171	4.987	6.082	6.994	8.498	9.739	10.812	11.765
0112	0.75	3.640	5.725	6.982	8.029	9.755	11.180	12.412	13.506
0127	0.80	4.141	6.513	7.944	9.135	11.099	12.721	14.122	15.367
0145	0.85	4.675	7.353	8.968	10.312	12.530	14.361	15.942	17.347
0162	0.90	5.241	8.244	10.054	11.561	14.048	16.100	17.873	19.448
0182	0.95	5.840	9.185	11.202	12.881	15.652	17.938	19.914	21.669
0202	1.00	6.471	10.177	12.412	14.273	17.343	19.876	22.065	24.010
0244	1.10	7.94	12.49	15.24	17.52	21.29	24.40	27.09	29.47
0293	1.20	9.52	14.97	18.26	21.00	25.52	29.24	32.46	35.33
0346	1.30	11.25	17.70	21.58	24.82	30.16	34.56	38.37	41.75
0404	1.40	13.14	20.67	25.21	28.99	35.22	40.37	44.82	48.77
0467	1.50	15.19	23.89	29.14	33.51	40.72	46.67	51.81	56.37
0535	1.60	17.40	27.38	33.39	38.39	46.65	53.46	59.35	64.58
0604	1.70	19.65	30.90	37.69	43.34	52.66	60.36	67.00	72.91
0678	1.80	22.03	34.65	42.26	48.60	59.05	67.67	75.13	81.75
0760	1.90	24.71	38.87	47.40	54.51	66.24	75.91	84.27	91.70
0865	2.00	28.13	44.25	53.96	62.06	75.40	86.42	95.94	104.39
0979	2.10	31.84	50.09	61.08	70.24	85.35	97.82	108.59	118.16
1102	2.20	35.81	56.33	68.69	78.99	95.98	110.00	122.12	132.88
1205	2.30	39.19	61.64	75.17	86.45	105.04	120.38	133.64	145.42
1313	2.40	42.67	67.12	81.85	94.13	114.37	131.08	145.52	158.34
1424	2.50	46.30	72.83	88.82	102.13	124.10	142.23	157.90	171.81
1540	2.60	50.08	78.77	96.06	110.47	134.23	153.84	170.78	185.83
1661	2.70	54.01	84.95	103.60	119.13	144.75	165.90	184.17	200.40
1787	2.80	58.08	91.35	111.41	128.12	155.67	178.41	198.06	215.52
1916	2.90	62.30	98.00	119.51	137.43	166.99	191.39	212.46	231.19
2051	3.00	66.67	104.87	127.90	147.07	178.71	204.81	227.37	247.41

INSTRUCTIONS

During manual operation of high-pressure spray guns and lances, which may be included recoil force in the longitudinal axis of the spray device may not exceed 250N!

If the recoil force is 150N, has been working with a body support!

	< 150 N
	< 250 N
	> 250 N